

## Product Information Bulletin

This Product Information Bulletin outlines the correct assembly procedure for RYCO JSEAL™ connections to ensure correct installation and that maximum performance is achieved.

In addition to SAE J2593 (Recommendations on Proper Wrench and Torque Wrench Usage) and SAE J514 (Recommended Assembly Procedures) RYCO JSEAL™ assembly shall be performed as per the instructions below.

**NOTE:** The assembly specifications herein are for RYCO JSEAL™ couplings as supplied; **no additional lubrication is to be used during the assembly process.**

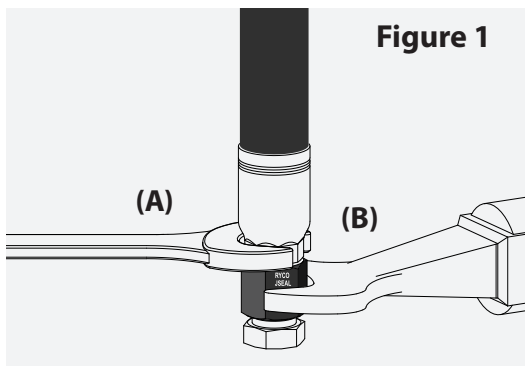

Figure 1

### ASSEMBLY PROCEDURE - STRAIGHT COUPLINGS

1. Hand-tighten the JSEAL™ nut onto the mating male connector.
2. Use a suitably sized wrench (A) to engage the octagon/hexagon to restrain the coupling body and prevent it from rotating.
3. While holding wrench (A) in position, engage torque wrench (B) and tighten the black JSEAL™ nut to the corresponding assembly torque value listed in Table 1 herein.

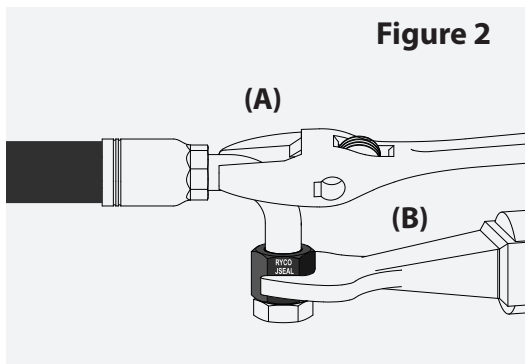

Figure 2

### ASSEMBLY PROCEDURE - 90° BEND COUPLINGS

1. Hand-tighten the JSEAL™ nut onto the mating male connector.
2. Use a suitably sized adjustable wrench (A) to engage the tube portion of the coupling body (as shown in Figure 2) to prevent it from rotating.
3. While holding wrench (A) in position, engage torque wrench (B) and tighten the black JSEAL™ nut to the corresponding assembly torque value listed in Table 1 herein.

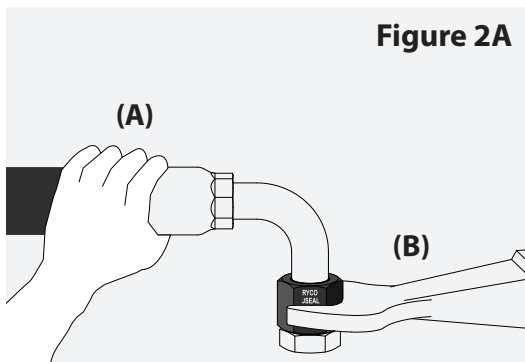
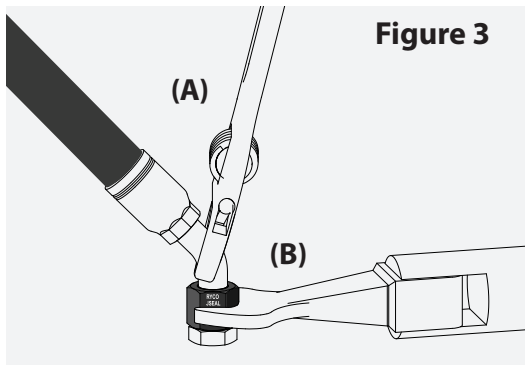

Figure 2A

### ALTERNATE ASSEMBLY PROCEDURE - 90° BEND COUPLINGS

1. Hand-tighten the JSEAL™ nut onto the mating male connector.
2. Using your hand (A), firmly restrain the coupling body (as shown in Figure 2A) to prevent it from rotating.
3. While holding coupling in position by hand (A), engage torque wrench (B) and tighten the black JSEAL™ nut to the corresponding assembly torque value listed in Table 1 herein.



**Figure 3**

### ASSEMBLY PROCEDURE - 45° BEND COUPLINGS

1. Hand-tighten the JSEAL™ nut onto the mating male connector.
2. Use a suitably sized adjustable wrench (A) to engage the tube portion of the coupling body (as shown in Figure 3) to prevent it from rotating.
3. While holding wrench (A) in position, engage torque wrench (B) and tighten the black JSEAL™ nut to the corresponding assembly torque value listed in Table 1 herein.

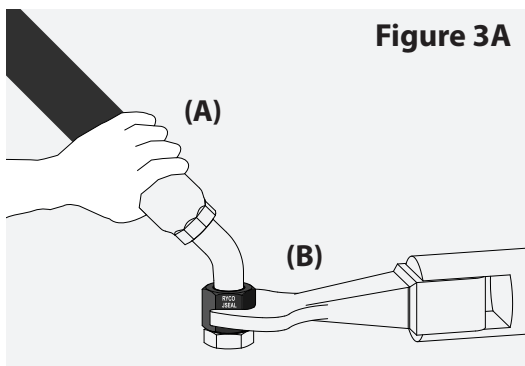

**Figure 3A**

### ALTERNATE ASSEMBLY PROCEDURE - 45° BEND COUPLINGS

1. Hand-tighten the JSEAL™ nut onto the mating male connector.
2. Using your hand (A), firmly restrain the coupling body (as shown in Figure 3A) to prevent it from rotating.
3. While holding coupling in position by hand (A), engage torque wrench (B) and tighten the black JSEAL™ nut to the corresponding assembly torque value listed in Table 1 herein.

**NOTE:** Failure to restrain the coupling body to prevent it from rotating during assembly may reduce the performance of the coupling.

RYCO JSEAL™ SIZE			RYCO JSEAL™ SPECIFICATIONS	
TUBE SIZE	THREAD SIZE	DASH SIZE	MAXIMUM WORKING PRESSURE	RECOMMENDED TORQUE SETTINGS
inch	inch		psi	ft.lb
1/4	7/16	-07	10100	17
3/8	9/16	-09	10100	29
1/2	3/4	-12	9100	57
5/8	7/8	-14	9100	105
3/4	1.1/16	-17	8100	146
7/8	1.3/16	-19	7100	173
1	1.5/16	-21	6100	194
1.1/4	1.5/8	-26	6100	228
1.1/2	1.7/8	-30	5100	285
2	2.1/2	-40	4100	440

**Table 1: RYCO JSEAL™ Assembly Torque and Performance Specifications**

Note: JSEAL 2" (-40) has a 3.5:1 safety factor.

To learn more about RYCO JSEAL™ visit us at: [www.RYCO.com.au/JSEAL](http://www.RYCO.com.au/JSEAL)

## RYCO USA & CANADA

P: +1 866 821 7926  
E: Product@RYCO.com.au



[www.RYCO.com.au](http://www.RYCO.com.au)

All Rights Reserved  
Copyright: April 2015  
Released: October 2019