



HOSE PROTECTION

Maximise the Service Life of your Hoses



STRONGER CONNECTIONS.
SMARTER SOLUTIONS.

www.ryco-hydraulics.com

HOSE PROTECTION – RCS CROCSLEEVE

RCS
CROCSLEEVE
FLAME RESISTANT
ANTI-STATIC



RECOMMENDED FOR:

Hose burst and pinhole protection and protection of individual hoses from severe abrasion. The CROCSLEEVE Provides a cost effective method of bundling hoses together, while providing abrasion resistance to the bundle. When abrasion occurs, the thousands of tiny filaments in the sleeve bulk up to continually renew the surface.

CONSTRUCTION:

Densely woven, polyamide tubular sleeve. Black or Red colour. The CROCSLEEVE is not affected by exposure to air, water, hydraulic oil and many other fluids. The inside bore of the CROCSLEEVE is smooth, allowing hose to move inside the sleeve, and allowing easy installation.

FRAS - FLAME RESISTANCE AND ANTI-STATIC:

Meets Flame Resistant Designation "U.S. MSHA" of the U.S. Department of Labor, Mine Safety and Health Administration. The CROCSLEEVE is both Flame Resistant and Anti-Static.

TEMPERATURE RANGE:

From -50°C to +121°C (-58°F to +250°F).

SIZE SELECTION:

Choose a size that is slightly larger than the hose or hoses to be sleeved - the recommended size is 50% larger than the nominal Hose OD. If the CROCSLEEVE is to be installed onto fitted hose assemblies, then allow for the maximum outside profile of the hose fittings.

ASSEMBLY INSTRUCTIONS:

1. Cut the CROCSLEEVE to length.
2. Seal the loose fibres of the cut edges with a heat gun or hot knife, to prevent fraying.
3. Install the CROCSLEEVE over the hoses or hose assemblies.
4. Secure in place using 2 x RCSTD-12 CROCTIES for hose sizes -3 to -12 or 3 x RCSTD-32 CROCTIES for hose sizes -16 to -32.

RCS CROCSLEEVE SPECIFICATIONS

CROCSLEEVE DIMENSIONS									
PART NO		NOMINAL ID		NOMINAL FLAT ID		NOMINAL FLAT OD		NOMINAL WEIGHT	
Black	RED	A mm	A inch	B mm	B inch	C mm	C inch	kg/m	lb/ft
RCSB-20	RCSR-20	20	0.79	31	1.22	34	1.34	0,039	0.026
RCSB-23	RCSR-23	23	0.91	36	1.42	39	1.54	0,044	0.030
RCSB-27	RCSR-27	27	1.06	42	1.65	45	1.77	0,052	0.035
RCSB-31	RCSR-31	31	1.22	49	1.93	52	2.05	0,060	0.040
RCSB-36	RCSR-36	36	1.42	54	2.13	57	2.24	0,065	0.044
RCSB-44	RCSR-44	44	1.73	69	2.72	72	2.83	0,082	0.055
RCSB-47	RCSR-47	47	1.85	74	2.91	77	3.03	0,086	0.058
RCSB-55	RCSR-55	55	2.17	86	3.39	89	3.50	0,102	0.068
RCSB-60	RCSR-60	60	2.36	94	3.70	97	3.82	0,111	0.074
RCSB-66	RCSR-66	66	2.60	104	4.09	107	4.21	0,122	0.082
RCSB-73	RCSR-73	73	2.87	115	4.53	118	4.65	0,135	0.091
RCSB-93	RCSR-93	93	3.66	146	5.75	149	5.87	0,170	0.114
RCSB-112	RCSR-112	112	4.41	176	6.93	179	7.05	0,206	0.138
RCSB-129	RCSR-129	129	5.08	202	7.95	205	8.07	0,360	0.241

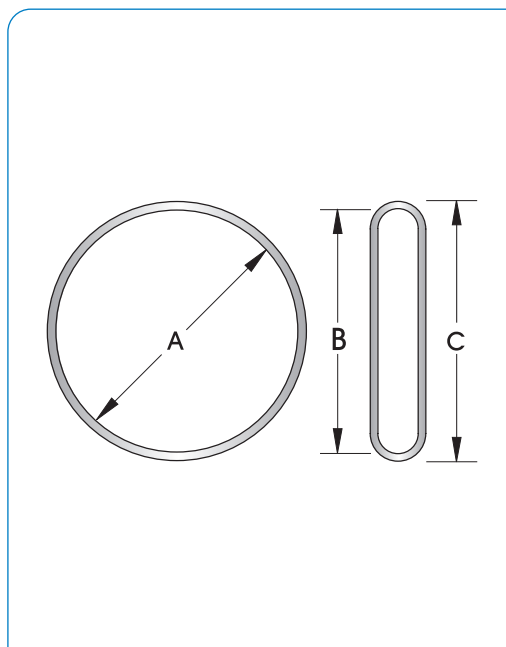

CROCSLEEVE SIZE VERSUS HOSE AND DASH SIZE SELECTION TABLE

Part No.	T3000D/S	T3600D/S	T4000D/S	T5000D/S	T6000D/S	H3000D/S	H4000D/S	H5000D/S	H6000D/S	H12D/S	R4SHD	R4SPD	T1D/S	T2D/S	D2B
BLACK	RED														
	Dash Size														
RCSB-20	RCSR-20	-04	-04	-04	-04	-04								-03,-04	
RCSB-23	RCSR-23	-05	-05	-05	-05	-05								-05	-04
RCSB-27	RCSR-27	-06	-06	-06	-06	-06								-06	-05
RCSB-31	RCSR-31	-08	-08	-08	-08			-06	-06	-06	-06		-06	-08	-06
RCSB-36	RCSR-36	-10	-10	-10	-10	-08		-08	-08	-08	-08		-08	-10	-08
RCSB-44	RCSR-44	-12	-12	-12	-12			-10	-10	-10	-10		-10	-12	-10,-12
RCSB-47	RCSR-47							-12	-12	-12	-12	-12	-12		
RCSB-55	RCSR-55	-16	-16	-16				-16	-16	-16		-16		-16	-16
RCSB-60	RCSR-60										-16		-16		
RCSB-66	RCSR-66							-20	-20			-20		-20	
RCSB-73	RCSR-73							-20	-20	-20	-20		-20	-24	-20
RCSB-93	RCSR-93							-24	-24	-24	-24	-24	-24	-32	-24
RCSB-112	RCSR-112							-32	-32	-32	-32	-32	-32		-32
RCSB-129	RCSR-129														-40

CROCSLEEVE - SAFETY FIRST

DESIGN FEATURES	BENEFITS
GREATER STRENGTH	CROCSLEEVE is made from high density PA (polyamide) for greater strength.
FLAME RESISTANT - ABRASION RESISTANT	CROCSLEEVE is Flame Resistant and Anti-Static - FRAS.
BURST RESISTANT	CROCSLEEVE is very resistant to hose burst.
PIN HOLE RESISTANT	CROCSLEEVE is very resistant to hose pin holes.
LEAK RESISTANT	CROCSLEEVE will allow pressure build up of up to 7 bar (100 psi).
STABLE	CROCSLEEVE is stable and has great resistance to sun, atmospheric agents and ageing.
NON-TOXIC	CROCSLEEVE is non toxic.
TOUGH	CROCSLEEVE is super tough.
COLOURS	CROCSLEEVE comes in BLACK (RCSB) and RED (RCSR).
EASY INSTALLATION	CROCSLEEVE has a smooth bore providing easy installation of the hose.

CHEMICALLY COMPATIBLE	Acetone	Very Good	Ether	Very Good
	Alcohols	Very Good	Gasoline	Very Good
	Bacterium	Very Good	Ionic Metallic Solutions	Very Good
	Benzene	Very Good	Mineral Oil	Very Good
	Carbon Tetrachloride	Very Good	Moths	Very Good
	Chlorine Based Solvents	Very Good	Mould	Very Good
	Diluted Acids	Good	Oil	Very Good
	Diluted Bases	Very Good	Vegetable Oil	Very Good

HOSE PROTECTION – RAWHIDE NYLON HOSE SLEEVE

RH RAWHIDE NYLON HOSE SLEEVE



RECOMMENDED FOR:

The protection of individual hoses from severe abrasion. The Ryco RAWHIDE provides a cost effective method of bundling hoses together, while providing abrasion resistance to the bundle. When abrasion occurs, the thousands of tiny filaments in the sleeve bulk up to continually renew the surface.

CONSTRUCTION:

Densely woven, multi-filament nylon, tubular sleeve. Black colour. Nylon is not affected by exposure to air, water, hydraulic oil and many other fluids. The inside bore of the sleeve is smooth, allowing hose to move inside the sleeve, and allowing easy installation.

FLAME RESISTANCE:

Meets Flame Resistant Designation "U.S. MSHA" of the U.S. Department of Labor, Mine Safety and Health Administration.

TEMPERATURE RANGE:

From -50°C to +121°C (-58°F to +250°F).

SIZE SELECTION:

Choose a size that is slightly larger than the hose or hoses to be sleeved. If a sleeve is to be installed on to fitted hose assemblies, allow for the maximum outside profile of the hose fittings.

ASSEMBLY INSTRUCTIONS:

1. Cut the Nylon Hose Sleeve to length.
2. The loose fibres of the cut edges can be sealed with a heat gun or hot knife, to prevent fraying.
3. Install over hoses or hose assemblies.
4. Secure in place using cable ties, band clamps or hose clamps.

STANDARD COIL LENGTHS:

91,4 metre (300 ft) long coils; or cut lengths.



RH RAWHIDE SPECIFICATIONS

RAWHIDE NYLON HOSE SLEEVE								
PART NO	NOMINAL ID		NOMINAL WALL THICKNESS		NOMINAL INSIDE FLAT DIMENSION		NOMINAL WEIGHT	
	A mm	A inch	B mm	B inch	C mm	C inch	kg/m	lb/ft
RH-23	22,9	0.90	2,3	0.09	29,8	1.41	0,06	0.03
RH-27	26,9	1.06	2,3	0.09	39,8	1.67	0,07	0.04
RH-31	31,0	1.22	2,3	0.09	49,9	1.92	0,08	0.05
RH-36	36,0	1.42	2,5	0.10	56,6	2.23	0,09	0.06
RH-46	46,0	1.81	2,5	0.10	72,1	2.84	0,12	0.08
RH-56	55,6	2.19	2,5	0.10	87,4	3.44	0,15	0.10
RH-61	60,5	2.38	2,5	0.10	95,0	3.74	0,16	0.11
RH-67	66,8	2.63	2,5	0.10	104,6	4.12	0,17	0.12
RH-73	73,2	2.88	2,5	0.10	115,1	4.53	0,19	0.13
RH-93	93,0	3.66	2,5	0.10	146,1	5.75	0,25	0.17

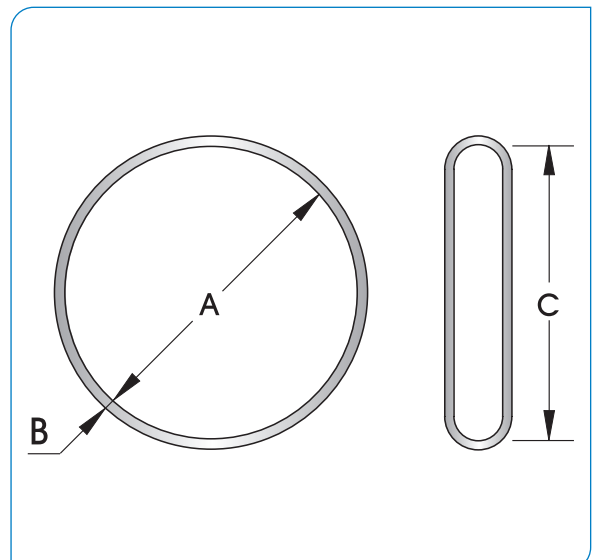

RSG

POLYETHYLENE SPIRAL GUARD
RSG (BLACK), RSGY (YELLOW), RSGF (FRAS)



RECOMMENDED FOR:

Lightweight, cost-effective protection of hoses and cables from abrasion and impact. The Ryco SPIRAL GUARD can also be used to bundle hoses together in groups. RSGF meets Flame Resistance Designation “U.S. MSHA” of the US Department of Labor, Mine Safety and Health Administration.

CONSTRUCTION:

Polyethylene plastic spiral, with rounded edges to protect hose cover. RSG Black; RSGY Yellow; RSGF FRAS (Dark Grey). Polyethylene is not affected by exposure to air, water, hydraulic oil and many other fluids.

TEMPERATURE RANGE:

From -40°C to +120°C (-40°F to +248°F).

ASSEMBLY INSTRUCTIONS:

The Ryco Spiral Guard can easily be applied after a hose assembly is complete because of its spiral form. Place one end of the completed hose assembly in a vice, then wrap the coil on to the hose. It is recommended to choose the Ryco Spiral Guard size so that it is a tight fit on the hose, this will keep it in place.

NOTE: The Ryco Spiral Guard expands to fit the hose or hose bundle. Allow extra length of Spiral Guard to allow for this expansion.

SIZE SELECTION:

The tables below show Ryco Spiral Guard size selection for a tight fit on the hose. Due to the Spiral Guard expanding to fit the hose, extra length of Spiral Guard must be allowed. This extra length can be estimated as follows:

T26D Nominal OD = 18,9 mm

RSG-20L Nominal ID = 15,0 mm (from chart below)

Estimated length of RSG-20L to cover 2,3 metres of T26D

$$= \frac{18,9}{15,0} \times 2,3 \text{ m} = 2,90 \text{ metres}$$

HOW TO ORDER:

Complete the Part Number: RSG-16L, RSGY-75L, RSGF-50L etc.

Sizes -16L to -90L: 20 m (65.6 ft) coils or cut to length.

Size -110L: 10 m (32.8 ft) coils or cut to length.

SPIRAL GUARD					HOSE SERIES																							
Dash size	Nominal ID		Nominal OD		T3000D/S	T3600D/S	T4000D/S	T5000D/S	T6000D/S	H3000D/S	H4000D/S	H5000D/S	H6000D/S	T1D/S	T1F	T2D/S	T2C	TXA2D	E2	TJ2D	H12D/S	R4SHD	R4SPD	T5	D2B	MS1000	CS1000	
	mm	inch	mm	inch																								
-12L	9,0	0.35	13,0	0.51	-4	-4	-4	-4						-3	-3													
-16L	12,0	0.47	16,5	0.65	-5,-6	-5,-6	-5	-5	-4,-5					-4,-5	-4,-5	-4	-4		-4	-4					-4,-5			
-20L	15,0	0.59	20,0	0.79	-8	-8	-6,-8	-6,-8	-6		-6	-6	-6	-6,-8	-6,-8	-5,-6	-5,-6		-5,-6	-5	-6		-6		-6,-8	-8	-8	
-25L	19,0	0.75	24,5	0.96	-10	-10	-8,-10		-8		-8	-8	-8	-10	-10	-8,-10	-8,-10	-8,-10	-8,-10		-8		-8		-10	-10	-10	
-32L	23,0	0.91	30,0	1.18	-12	-12	-12	-10,-12			-10,-12	-10,-12	-10,-12	-12	-12	-12	-12	-12	-12		-10,12		-10		-12	-12	-12	
-40L	30,5	1.20	39,0	1.54	-16	-16	-16	-16			-16	-16	-16	-16	-16	-16	-16	-16	-16		16	-12,-16	-12,16	-16,-20	-16	-16	-16	
-50L	38,0	1.50	46,5	1.83						-20	-20	-20	-20	-20	-20	-20	-20	-20	-20		-20	-20	-20	-24		-20,-24	-20,-24	
-63L	47,0	1.85	58,0	2.28						-24	-24	-24	-24	-32	-24	-24	-24	-24	-24		-24	-24	-24	-32	-24	-32	-32	
-75L	61,0	2.40	73,0	2.87						-32	-32	-32	-32			-32,-40	-32				-32	-32	-32		-32			
-90L	70,5	2.78	84,5	3.33												-48					-40							
-110L	84,0	3.31	99,0	3.90																								

Dash size	Nominal ID		Nominal OD		BT1	RQP1	RQP2	RQP5	RQP6	TW1	PW2	SR	SRF	RTH1	FB2	M1	MP1	M2	PL1	PL1D	M2G	TP7, TP7N	TP7T, TP7TN	TP8, TP8N	TP8T, TP8TN	TP3000	TP6L
	mm	inch	mm	inch																							
-12L	9,0	0.35	13,0	0.51		-4	-4	-4						-4,-6	-4			-4	-4	-4		-4	-4	-4	-4	-4	-2
-16L	12,0	0.47	16,5	0.65	-4,-5	-5	-4	-5	-5,-6		-4			-8	-6	-5,-6		-4	-5,-6	-5,-6		-5,-6	-5,-6	-6	-6	-6	
-20L	15,0	0.59	20,0	0.79	-6	-6,-8	-5,-6	-6,-8	-8		-5,-6			-10	-6		-4	-6	-8	-8	-4,-6	-8	-8	-8	-8	-8	
-25L	19,0	0.75	24,5	0.96	-8,-10	-10	-8,-10	-10	-10	-8				-12	-8		-8,-10	-8	-10	-10	-8					-8	
-32L	23,0	0.91	30,0	1.18	-12	-12	-12	-12	-12					-12	-8		-12	-12	-12	-12	-12						-8
-40L	30,5	1.20	39,0	1.54	-16	-16	-16	-16,-20						-12			-16	-16	-16	-16	-16						
-50L	38,0	1.50	46,5	1.83			-20	-24					-16	-16			-20										
-63L	47,0	1.85	58,0	2.28			-24	-32					-20,-24														
-75L	61,0	2.40	73,0	2.87			-32						-32														
-90L	70,5	2.78	84,5	3.33									-40														
-110L	84,0	3.31	99,0	3.90									-48														

HOSE PROTECTION – RWA WIRE ARMOUR

RWA
WIRE ARMOUR

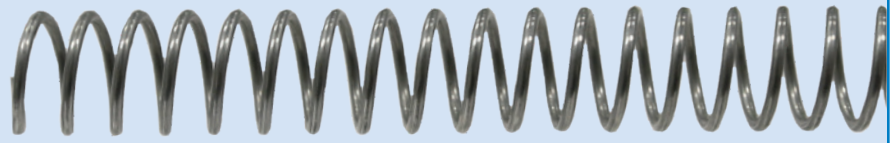

RECOMMENDED FOR:

The protection for a Hose Cover in arduous operating conditions; especially against abrasion and deep gouges, thus prolonging the life of the Hose.

CONSTRUCTION:

Spring Steel Wire; galvanised for corrosion protection.

TEMPERATURE RANGE:

Suitable for use with all Ryco Hoses at their published temperature ranges.

ASSEMBLY INSTRUCTIONS:

1. Slide the RWA Wire Armour over a hose after the first end of the hose assembly is completed.
2. Complete second end of the hose assembly.

STANDARD LENGTH:

6 metres (19.7 ft) in all sizes.

WIRE ARMOUR			HOSE SERIES																					
PART NO	Nominal ID		T3000D/S	T3600D/S	T4000D/S	T5000D/S	T6000D/S	H3000D/S	H4000D/S	H5000D/S	H6000D/S	T1D/S	T2D/S	T2C	TXA2D	E2	TJ2D	H12D/S	R4SHD	R4SPD	T5	D2B	MS1000	CS1000
	mm	inch																						
RWA-12	12	0.47																						
RWA-16	16	0.63	-4,-5	-4,-5	-4	-4	-4					-4,-5	-4			-4						-4,-5		
RWA-20	20	0.78	-6	-6	-5,-6	-5,-6	-5,-6					-6	-5	-4,-5		-5	4					-6		
RWA-21	21	0.83	-8	-8					-6	-6	-6	-6	-6	-6	-6	-5						-8	-8	-8
RWA-23	23	0.91			-8	-8	8					-8	-8		-8	-8		-6	-6					
RWA-27	27	1.06	-10	-10	-10	-10			-8,-10	-8	-8	-10		-8,-10		-10		-8	-8	-8	-10		-10,-12	-10,-12
RWA-30	30	1.19	-12	-12	-12	-12				-10	-10	-12	-10		-10			-10	-10	-12				
RWA-31	31	1.22								-12	-12	-12	-12	-12	-12	-12								
RWA-34	34	1.34							-12	-12	-12	-12	-12	-12	-12	-12		-12	-12	-12	-16		-16	-16
RWA-39	39	1.52	-16	-16	-16				-16	-16	-16	-16	-16	-16	-16	-16			-16					
RWA-41	41	1.61										-16	-16	-16	-16	-16		-16	-16	-16	-20		-20	-20
RWA-49	49	1.93						-20	-20	-20	-20	-20	-20	-20	-20	-20		-20	-20	-20	-24		-24	-24
RWA-56	56	2.2						-24	-24	-24	-24	-24	-24	-24	-24	-24			-24	-24	-20	-24		-24
RWA-61	61	2.4																		-24	-32		-32	-32
RWA-68	68	2.68						-32	-32			-32	-32	-32					-32			-32		
RWA-75	75	2.95								-32	-32								-32	-32				

PART NO	Nominal ID		BT1	RQP1	RQP2	RQP5	RQP6	TW1	PW2	SR	SRF	RTH1	FB2	M1	MP1	M2	PL1	PL1D	M2G	TP7, TP7N	TP7T, TP7TN	TP8, TP8N	TP8T, TP8TN	TP-3000	TPGL
	mm	inch																							
RWA-12	12	0.47										-4									-3				-2
RWA-16	16	0.63	-4,-5	-4,-5	-4	-4,-5	-4,-5					-6,-8		-4,-5	-4	-4	-4,-5	-4,-5	-4		-4,-5	-4,-5	-4	-4	-4
RWA-20	20	0.78	-6	-6	-5	-6	-6	-6	-4,-5					-6	-6		-6	-6			-6	-6	-6	-6	-6
RWA-21	21	0.83			-6	-8	-8					-10	-6			-6	-8	-8	-6			-8	-8		
RWA-23	23	0.91	-8	-8	-8			-8					-8	-8							-8	-8			
RWA-27	27	1.06	-10	-10		-10	-10					-12	-10		-10	-8	-10	-10	-8					-8	
RWA-30	30	1.19	-12	-12	-10	-12	-12								-12	-12	-12	-12			-12				
RWA-31	31	1.22			-12							-16													
RWA-34	34	1.34				-16													-12						
RWA-39	39	1.52	-16								-12	-12									-16				
RWA-41	41	1.61		-16	-16	-20					-16	-16													
RWA-49	49	1.93			-20	-24					-20														
RWA-56	56	2.2			-24						-24														
RWA-61	61	2.4				-32																			
RWA-68	68	2.68			-32						-32														
RWA-75	75	2.95																							

FS1072

FIRE SLEEVE



MEETS OR EXCEEDS THE PERFORMANCE REQUIREMENTS OF:
SAE AEROSPACE STANDARD AS 1072.

RECOMMENDED FOR:

Increasing service life of hoses used in hostile environments. The Ryco FIRE SLEEVE is a tough, flexible insulation, which not only protects from intense external radiant heat, but also sheds molten metal splash. Consequently, damage to hoses is reduced and service life is increased. In the event of fire, hoses carrying flammable or hazardous materials remain intact longer. It can also be used to protect cables, pipes and wire ropes.

The Ryco FIRE SLEEVE can also be used to reduce heat loss from hoses.

CONSTRUCTION:

The Ryco FIRE SLEEVE is manufactured from high bulk braided glass fibre tubing, coated with silicon rubber. The "danger red" colour of the silicon rubber is due to heavy loading of iron oxide to improve heat resistance.

TEMPERATURE RANGE:

Continuous exposure:

from -54°C to +260°C (-65°F to +500°F)

15 to 20 minutes:

from +260°C to +1090°C (+500°F to +2000°F)

15 to 30 seconds:

from +1090°C to +1640°C (+2000°F to +3000°F)

TYPICAL PROPERTIES:

K Value in $\frac{\text{BTU}}{^{\circ}\text{F}\cdot\text{hr}\cdot\text{in}^2}$ 1.20

K Value in $\frac{\text{Cal}}{\text{cm}\cdot\text{sec}\cdot\text{cm}^2\cdot^{\circ}\text{C}}$ 0.0004134

FLAME RESISTANCE:

7 seconds to extinguish with no afterglow.

ABRASION RESISTANCE:

Wyzenbeck 9500 cycles, 3.1/3 lb pressure, 6 lb tension using fine emery cloth.

OIL AND FLUID RESISTANCE:

Remains functional after immersion for 120hr @ 80°F in MIL-H-5606, MIL-L-6082, Skydrol 500 LD and Skydrol 500.

SIZE SELECTION:

The Ryco FIRE SLEEVE performs best when installed with a loose fit over a hose. However, some end users insist on a tight fit for the sake of appearance. To achieve this tight fit, use compressed air to expand the Ryco FIRE SLEEVE as it is installed over the hose. Length of the Ryco FIRE SLEEVE will shorten in length as it increases in diameter, therefore allow for some extra length to compensate for this.

For a loose fit, there is no hard and fast rule to relate the Nominal Inside Diameter of the Ryco FIRE SLEEVE with the Nominal Outside Diameter of the hose being covered. However, it is important to take two factors into account: hose length and hose cover.

For hoses up to 5 metres (16 ft) long, use a Nominal Inside Diameter of the Ryco FIRE SLEEVE 15% larger than the Nominal Outside Diameter of hose being covered. For hoses over 5 metres (16 ft) long, use a size 20% larger. Remember the Ryco FIRE SLEEVE must slide over the outside of the hose. The longer the hose, the tougher it is to install, especially if enough tolerance on a long hose has not been allowed.

As the Ryco FIRE SLEEVE must slide over the outside of the hose, the hose covering also requires special consideration. A hose with a rough rubber cover is more difficult to slide the Ryco FIRE SLEEVE over than a hose with a smooth cover. For hose covers that have a high co-efficient of friction, be sure to allow for greater tolerance between the Nominal Inside Diameter of the Ryco FIRE SLEEVE and the Nominal Outside Diameter of the hose to be covered.

For sizes FS1072-08 to FS1072-104:

The standard coil length is 15,24 metres (50 ft); or cut lengths. Lengths longer than 15,24 meters (50 ft) are also available, contact Ryco Customer Service for more information.

For sizes FS1072-80 and FS1072-104:

The standard coil length is 5 metres (16.4 ft)

The Ryco FIRE SLEEVE can be slit longitudinally to form a flat FIRE TAPE which can be wound around larger diameter hoses and secured with stainless steel ties or FSTAPE-16.

FSTAPE-16

FSTAPE-16 is an iron oxide, red silicone rubber tape. It is designed to be not only self-bonding and self-curing, but to also bond and cure onto the Ryco FIRE SLEEVE. It can be used to join separate sections of the Ryco FIRE SLEEVE, as well as to repair any scuffed or nicked areas of the Ryco FIRE SLEEVE. It can be used as an end sealant (instead of clamps) to prevent moisture and hydraulic oils wicking into the inner fibreglass braid.

FSTAPE-16 is supplied in a roll 25 mm WIDE x 11 metres LONG x 0,5 mm THICK (1 inch x 36 ft x 0.02 inch)



HOSE PROTECTION – FS1072 FIRE SLEEVE

FS1072 FIRE SLEEVE SPECIFICATIONS

FIRE SLEEVE DIMENSIONS								
PART NO	NOMINAL ID		NOMINAL WALL THICKNESS		NOMINAL INSIDE FLAT DIMENSION		NOMINAL WEIGHT	
	A mm	A inch	B mm	B inch	C mm	C inch	kg/m	lb/ft
FS1072-08	12,7	0.50	4,3	0.17	20,0	0.79	0,19	0.13
FS1072-11	17,5	0.69	4,3	0.17	27,5	1.08	0,29	0.19
FS1072-14	22,2	0.87	4,4	0.17	34,9	1.37	0,28	0.19
FS1072-16	25,4	1.00	4,8	0.19	39,9	1.57	0,31	0.21
FS1072-18	28,6	1.13	4,7	0.19	46,6	1.84	0,37	0.25
FS1072-20	31,8	1.25	4,7	0.19	47,4	1.87	0,36	0.24
FS1072-22	34,9	1.38	4,8	0.19	54,8	2.17	0,43	0.29
FS1072-24	38,1	2.50	4,0	0.16	58,3	2.29	0,46	0.31
FS1072-30	47,6	1.87	4,0	0.16	74,8	2.93	0,54	0.36
FS1072-32	50,8	2.00	4,0	0.16	79,8	3.14	0,55	0.37
FS1072-40	63,5	2.50	4,1	0.16	94,2	3.71	0,84	0.56
FS1072-44	69,9	2.75	5,0	0.20	109,8	4.32	0,85	0.57
FS1072-64	102,0	4.02	5,0	0.20	160,2	6.32	1,07	0.72
FS1072-80	127,0	5.00	5,0	0.20	199,5	7.89	2,26	1.52
FS1072-104	165,0	6.50	5,0	0.20	259,2	10.21	2,86	1.92

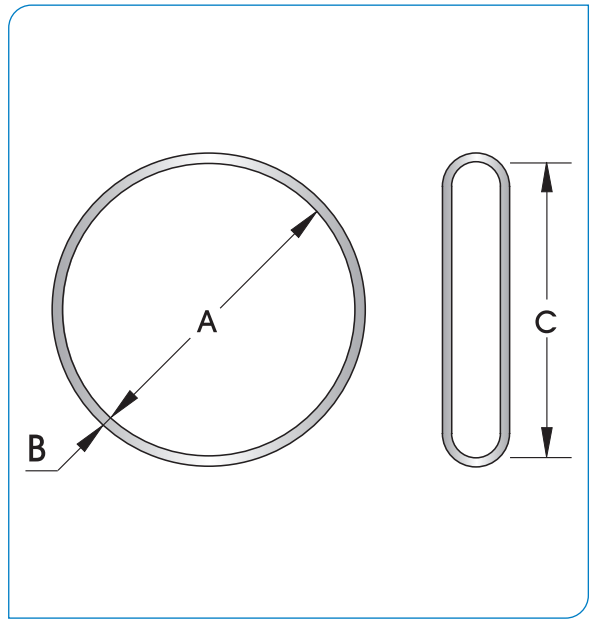

HOSE NOMINAL OUTSIDE DIAMETER REFERENCE CHART

This chart may be used as a quick reference to assist in choosing correct size of Hose Protection. The dimensions are nominal only, and are in millimetres. Divide by 25.4 to convert to inches.

HOSE SIZE			HOSE SERIES																										
DN	inch	Dash	T3000D/S	T3600D/S	T4000D/S	T5000D/S	T6000D/S	H3000D/S	H4000D/S	H5000D/S	H6000D/S	T1D/S	T1F	T2D/S	T2C	TXA2D	E2	TJ2D	H12D/S	R4SHD	R4SPD	T5	D2B	MS1000	CS1000				
3	1/8	-02																											
5	3/16	-03										11,7	11,7																
6	1/4	-04	11,8	11,8	11,8	13,2	13,2					13,3	13,3	14,9	15,0		14,9	14,9				13,2							
8	5/16	-05	14,4	14,4	15,6	15,6	15,6					14,9	14,9	16,5	16,6		16,5	18,9				14,8							
10	3/8	-06	15,6	15,6	16,6	17,1	17,6		19,3	19,3	19,3	17,3	17,3	18,9	19,0		18,9		19,3		20,9	17,2							
12	1/2	-08	18,7	18,7	20,6	20,6	21,5		22,7	22,7	22,7	20,3	20,3	21,9	22,2	22,0	21,9		22,7		24,3	19,4		18,5	18,5				
16	5/8	-10	23,4	23,4	23,4	24,8			24,9	26,2	26,2	23,6	23,6	25,1	25,2	25,2	25,1		26,2		27,8	23,4		22,1	22,1				
19	3/4	-12	27,6	27,6	28,4	27,8			30,0	29,6	30,6	27,6	27,6	29,1	29,1	29,1	29,1		30,0	31,8	31,8	27,4		25,8	25,8				
25	1	-16	34,8	34,8	35,2				36,9	36,8	37,5	35,5	35,5	37,5	37,2	37,7	37,5		37,4	37,9	38,6	31,4		32,5	32,5				
31	1.1/4	-20						45,7	44,0	45,0	46,4	43,2		47,6	47,4				45,7	44,4	49,6	38,1		39,5	39,5				
38	1.1/2	-24						50,3	50,8	52,7	53,1	50,2		54,1	53,8				53,0	52,4	56,0	44,5	48,1	46,0	46,0				
51	2	-32						63,3	66,4	67,5	71,5	63,6		66,8	66,7				66,0	66,8	68,9	56,3	61,8	59,1	59,1				
63	2.1/2	-40												80,1					82,6										
76	3	-48												93,4															

DN	inch	Dash	BT1	RQP1	RQP2	RQP5	RQP6	TW1	PW2	SR	SRF	RTH1	FB2	M1	MP1	M2	PL1	PL1D	M2G	TP7, TP7N	TP7T, TP7TN	TP8, TP8N	TP8T, TP8TN	TP3000	TPGL
3	1/8	-02																							8,3
5	3/16	-03																		9,6					
6	1/4	-04	13,3	13,4	15,0	13,2	12,7		15,0			9,4		12,7	13,5	14,3	12,3	12,3	14,3	12,2	12,2	11,5	11,5	12,2	
8	5/16	-05	14,9	15,0	16,6	14,8	14,3		16,6					14,3			13,9	13,9		14,3	14,3				
10	3/8	-06	17,3	17,4	19,0	17,2	15,9	17,4	19,0			11,7	19,0	15,9	17,5	19,0	15,5	15,5	19,0	16,0	16,0	15,5	15,5	16,6	
12	1/2	-08	20,3	20,5	22,0	19,4	19,8	20,6				15,4	23,0		21,4	23,8	19,0	19,0	23,8	20,3	20,3	19,9	19,9	22,5	
16	5/8	-10	23,6	23,7	25,2	23,4	23,0					18,4	25,4		25,4		22,6	22,6							
19	3/4	-12	27,6	27,6	29,1	27,4	26,4			31,5	31,5	22,1		28,6	31,7	25,8	25,8	31,7	27,1						
25	1	-16	35,5	35,7	37,7	31,4				40,0	40,0	28,6		37,3					34,0						
31	1.1/4	-20			48,0	38,1						46,5		43,9											
38	1.1/2	-24			54,4	44,5						53,1													
51	2	-32			67,3	56,3						65,5													
63	2.1/2	-40									78,5														
76	3	-48									90,7														

750/760 SPRING GUARD



RECOMMENDED FOR:

TJ24D and TJ26D Specialist Jacking Hose Assemblies, to control bend radius at the end of hoses to avoid excessive strain on hose couplings. SPRING GUARDS can also be used with **PW24, PW26, T24C, T24D, T24S, T26C, T26D** and **T26S** Hoses. They can be used with **L000** Series Field Attachable and **T2000** Series BITELOK Couplings.

- 750** Suits some -4 (1/4") and -6 (3/8") hoses
- 760** Suits some -6 (3/8") hoses

CONSTRUCTION:

Spring Steel Wire; galvanised for corrosion protection.

ASSEMBLY INSTRUCTIONS:

Slide the SPRING GUARD over the hose before assembling hose ends. After ends are assembled, twist and push the SPRING GUARD onto the ferrules. The close pitched end of the SPRING GUARD goes over the ferrule, and the wide pitched end goes over the hose (as depicted in the image below).



DISCLAIMER: We reserve the right to modify our products and/or related services and/or discontinue the manufacture and/or supply of any of the products and/or related services, without notice. This document supersedes all previous versions and previously issued documentation. The only official source of technical crimping parameters regarding our products is our Digital Crimp Tools. Printed copies are uncontrolled therefore, please be sure to use the latest versions of our Ryco [Crimp App](#) or [Crimp Web Tool](#). Don't mix and match: always use Ryco original hoses and fittings. For more information, see our [Safety Guide](#).

HOSE PROTECTION – RHYS PACKAGING SLEEVE

RHYS PACKAGING SLEEVE



RECOMMENDED FOR:

Packaging and protection of hose assemblies, in transit and in storage. The Ryco RHYS Packaging Sleeve is installed over the finished hose assembly. The ends may be heat sealed, or folded over and stapled, or taped closed.

CONSTRUCTION:

Heavy gauge low density polyethylene clear plastic tubing; printed at intervals with “Ryco” logo, and incorporating an area for the hose assembly Part Number to be written.

ASSEMBLY INSTRUCTIONS:

1. Select correct size of Ryco RHYS Packaging Sleeve. It must be large enough to allow for the maximum outside profile of the hose couplings.

Two sizes are available:

RHYS-75 suits most hoses up to -16 (1”) hose bore.

RHYS-125 suits most hoses from -16 to -32 (1” to 2”) hose.

2. If required, write the hose assembly Part Number onto the Packaging Sleeve using a ball point pen.
3. Slide the hose assembly into the RHYS Packaging Sleeve.
4. Trim Packaging Sleeve to length, and seal ends.

STANDARD COIL LENGTHS:

350 metres (1,150 feet).

RHYS HOSE ASSEMBLY PACKAGING SLEEVE SPECIFICATIONS

PART NO	NOMINAL ID		NOMINAL WALL THICKNESS		NOMINAL INSIDE FLAT DIMENSION		NOMINAL WEIGHT	
	A mm	A inch	B mm	B inch	C mm	C inch	kg/m	lb/ft
RHYS-75	48	1.9	0,15	0.006	75	3.0	0,021	0.014
RHYS-125	79	3.1	0,15	0.006	125	5.0	0,035	0.023

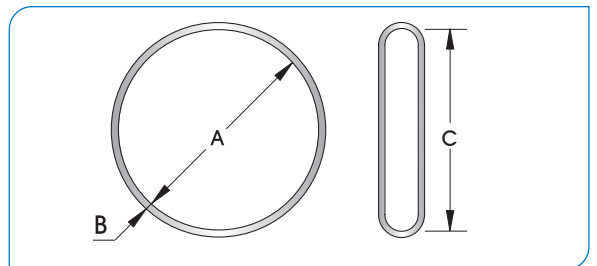

RHYT/RHWT

HOSE TAG



RECOMMENDED FOR:

The permanent identification of hose assemblies. Ryco Hose Tags enable hose assembly information to be attached to the hose assembly in a cost effective manner.

Two sizes of Hose Tags allow all common hose sizes to be tagged.

Information can be written or printed on the Hose Tag prior to being attached to the hose. When the Hose Tag is wrapped on the hose, a clear panel at the end of the tag wraps over to protect the written or printed information.

The Hose Tag remains in position on the hose due to the adhesive backing, and the Hose Tag bends with the hose, ensuring that flexibility is not affected.

The slim profile of the attached Hose Tag reduces the risk of accidental removal. The Hose Tag does not damage or cut the cover of the hose.

CONSTRUCTION:

Heat, oil, ozone, sunlight, and weather resistant high performance plastic.

Adhesive-backed for permanent attachment to the hose assembly. Area to write or print information, with a clear panel that wraps over to protect the hose assembly identification information.

TEMPERATURE RANGE:

Suitable for use with all Ryco Hoses at their published temperature ranges.

ASSEMBLY INSTRUCTIONS:

1. Select the correct size of the Ryco RHYT Hose Tag for the hose assembly that is to be identified.

Two sizes are available:

RHYT-10 and **RHWT-10** suits hose sizes -04 to -10 (1/4" to 5/8").

RHYT-32 and **RHWT-32** suits hose sizes -12 to -32 (3/4" to 2").

2. Using a ball point pen or label printer, apply the required information on to the Hose Tag.
3. Remove the release paper from the back of the Hose Tag to expose the adhesive.
4. While ensuring that the Hose Tag is parallel to the axis of the hose, wrap the Hose Tag tightly around the hose, then continue to wrap the clear plastic panel over the Hose Tag.
5. Press firmly to ensure that the adhesive bonds.

RHYT HOSE TAGS SPECIFICATIONS

RHYT/RHWT HOSE TAGS			
PART NO	SUITS HOSE SIZE ID RANGE		
	DN	INCH	DASH
RHYT-10	6 to 16	1/4 to 5/8	-04 to -10
RHYT-32	12 to 51	3/4 to 2	-12 to -32
RHWT-10	6 to 16	1/4 to 5/8	-04 to -10
RHWT-32	12 to 51	3/4 to 2	-12 to -32

Contact Ryco for further information.



RYCO®



SCAN HERE FOR
CONTACT INFORMATION